

(19)
(12)

(KR)
(A)

(51) 。 Int. Cl. ⁷
E21C 37/00

(11)
(43)

2003 - 0025034
2003 03 28

(21) 10 - 2001 - 0057943
(22) 2001 09 19

(71) 73 - 1
7 - 23

(72) 810 903 - 806
2 210 - 1101

(74)
:

(54)

가 .

4

1

2

3

4

5

<

>

10: 11:

20: 30:

31: 40:

41, 41a: 100:

110: 120:

130: 200:

210: 220:

230: 300:

310: 400:

410: 500:

510: 1 520: 1

530: 2 540: 2

550:

가

가

가

가

1

가

2

(41a)

(30)

가

1

(10)

(20)가

(30)

(10)

(30)

(31)

(10)

(10

(30)

(20)

(10)

(20)

3

4

(110),

(11

0)가

(10)가
가

가

(120),

가

(120)가

(130)

(100),

(130)

(220),

(210)

(220)가

(210)

(31)

(230)

(200),

(230)

(31)

(310)

(200)

(

300),

(400) - 3 4

-

(30) (31) (10) (30) (41)

(10)가 (30) (31) (20) (11) (41) (310)

(10) (10) (200) (220) (10)

(10) (10) (100) (120) (11) (41)

(20) (100) (10) (10) (100) (130)

(510), (510) (530), (530) (520), (520),

(540), (510) (530)가 (530)가 (550)

1 (500) (200) (210) (500) (550)

(100) (130) 2 (520, 540) 2 (520, 540) (520, 54)

(510, 530) 500) 0) 2 (550) (510, 530)가 (520, 540) (510, 530)

(550) 가 (520, 540) (510, 530) (100)

(130) (510, 530)가 (550) 가 가 (520, 540) 가

가 , 2 (130) (520, 540) (130) 가

(100) (130) , 2 (520, 540) (100) (130) 가

(31) (10) 가 , (300)

(310) 가 .

가 5 (120) (410) , (120)

가 가 가

가 , ,
가 .

가 .

(57)

1.

가 , 가 가 , 가 가 , 가 ;
가 ;
가 ;
;

2.

1 , 1 2 , 1 2 1 2 , 1 2 1 2
1 2 가 1 2 1 2 ,
2 1 가 가 1 2 1 2 1 2

1

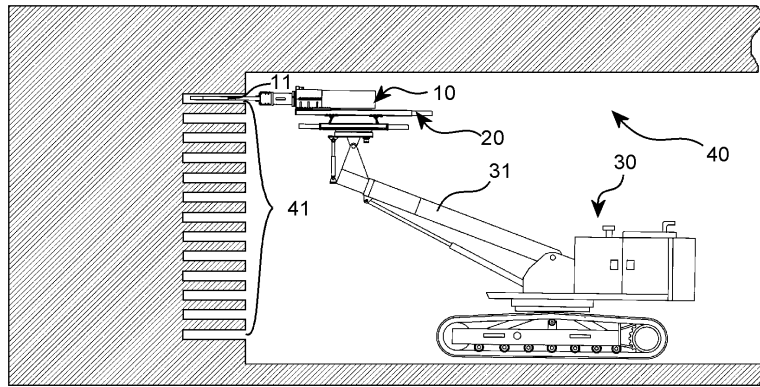

2

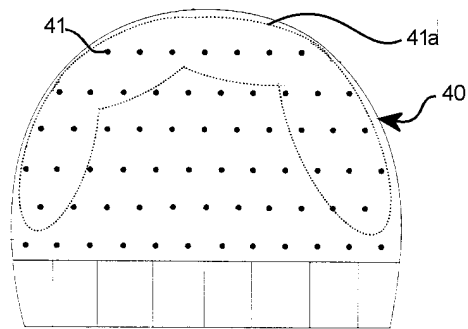

3

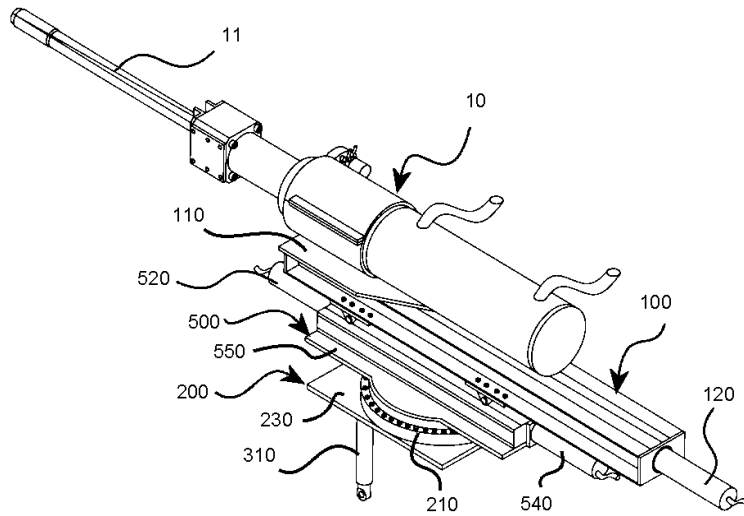

4

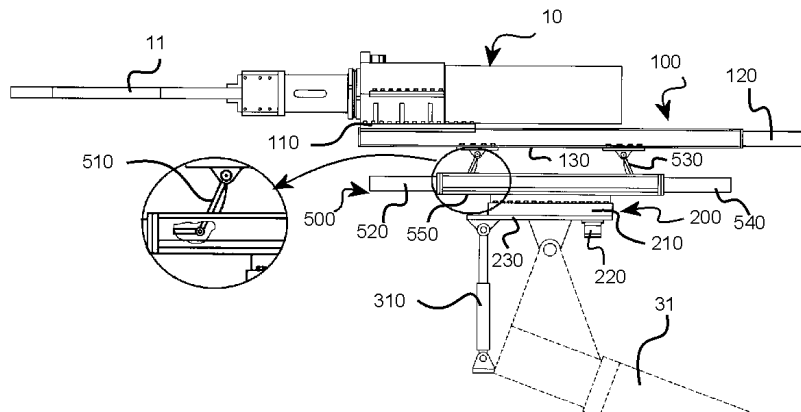

5

